

PERSIANAS

HERNANDO, S.A.



CIERRES

**CATÁLOGO
DE PRODUCTO**

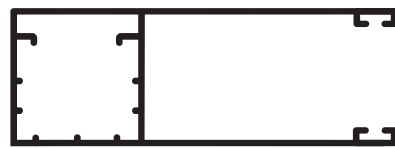

CIERRES

- Secciones de los Perfiles de Lama
 - Tabla de enrollamientos
 - Características técnicas
- Gama de Colores Estándar de Lama de Aluminio de Extrusión
- Gama de Carriles Compatible

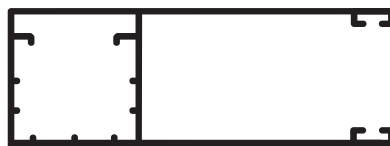

SECCIONES DE LOS PERFILES DE LAMA

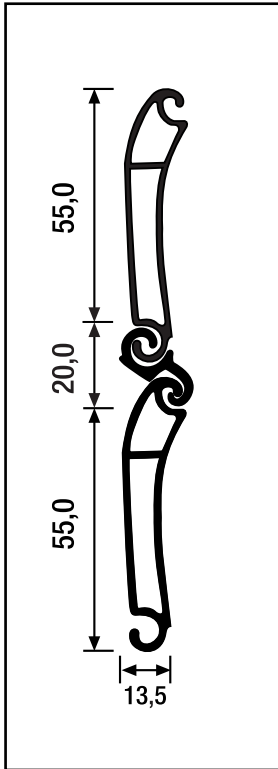

65 mm
Lama aluminio extrusión
doble pared.
Perfil curvo
autoblocante 65,0 mm

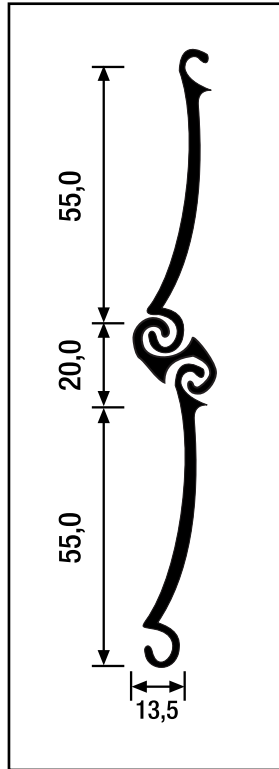

75 mm
Lama aluminio extrusión
monopared.
Perfil curvo
autoblocante 75,0 mm

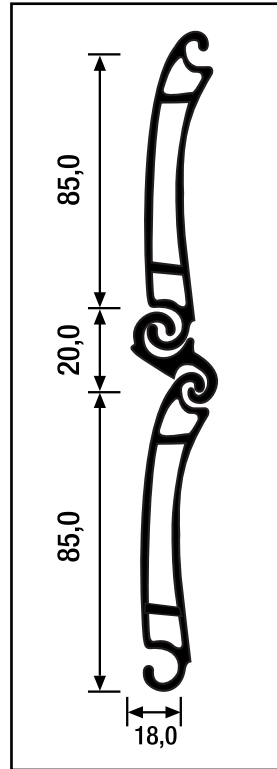

95 mm
Lama aluminio extrusión
doble pared.
Perfil curvo
autoblocante 95,0 mm

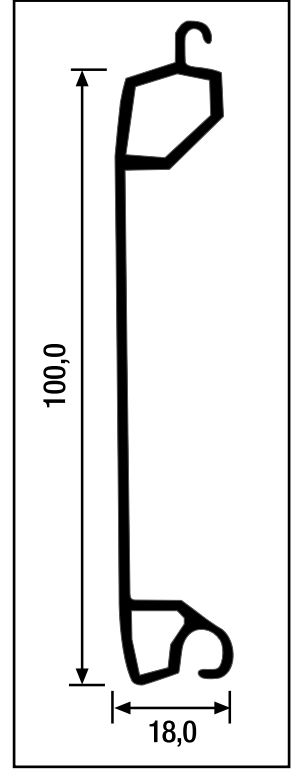

100 mm
Lama aluminio extrusión
monopared.
Perfil curvo
autoblocante 100,0 mm

+DRONES

¿Sueñas con volar?



SECCIONES DE LOS PERFILES DE LAMA

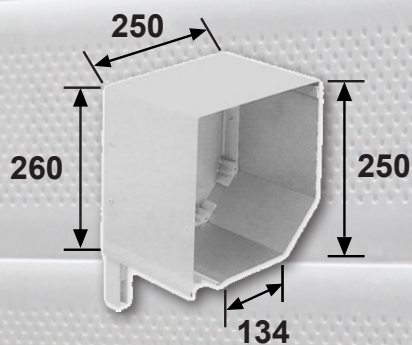

Aluminio 250 mm

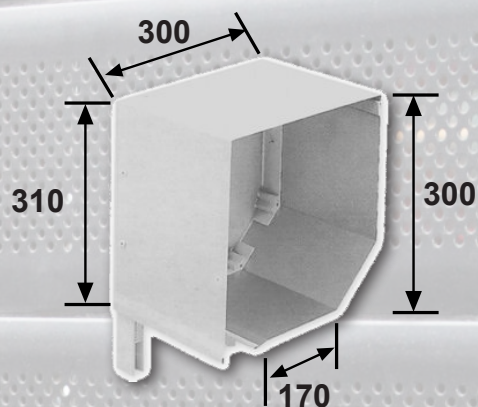

Aluminio 300 mm

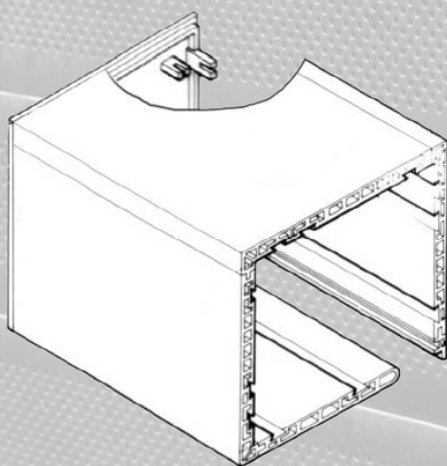

300 mm PVC

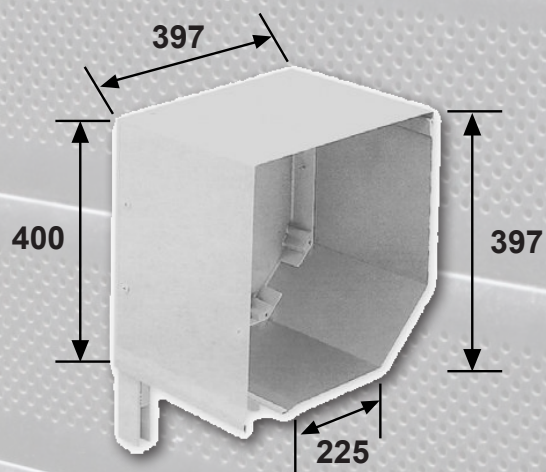

Aluminio 400 mm

	250 mm alu	300 mm alu	300 mm PVC	400 mm alu
Largo de producción	5,80 ml	5,80 ml	5,80 ml	5,80 ml
Embalaje	Film plástico	Film plástico	Film plástico	Film plástico
Suministro	2 tiras	2 tiras	1 tira	2 tiras

TABLA DE ENROLLAMIENTOS

	AUTOBLOCANTE 65,0 mm	AUTOBLOCANTE 75,0 mm	AUTOBLOCANTE 95,0 mm	100 mm
Altura	Eje 89	Eje 89	Eje 133	Eje 133
160 mm	205 mm	205 mm	245 mm	240 mm
200 mm	220 mm	220 mm	260 mm	255 mm
240 mm	240 mm	240 mm	280 mm	275 mm
280 mm	255 mm	255 mm	300 mm	290 mm
320 mm	270 mm	265 mm	310 mm	305 mm
360 mm	285 mm	280 mm	325 mm	315 mm
400 mm	295 mm	-	340 mm	330 mm
460 mm	-	-	360 mm	345 mm
500 mm	-	-	375 mm	360 mm

CARACTERÍSTICAS TÉCNICAS

	65,5 mm	75,0 mm	95,5 mm	100,0 mm
Alto lama	65,5 mm	75,0 mm	65,5 mm	65,5 mm
Espesor	13,5 mm	13,5 mm	18,0 mm	18,0 mm
Peso aproximado	11,80 kg/m ²	13,50 kg/m ²	14,00 kg/m ²	8,75 kg/m ²
Número de lamas/ml altura	15,0	13,3	13,3	13,3
Ancho máximo Aconsejado	4,25 ml	4,50 ml	7,00 ml	4,75 ml
Altura Máxima Aconsejada	3,00 ml	3,50 ml	5,00 ml	4,00 ml
Enrollamiento Sobre Eje Mínimo	89 mm	89 mm	133 mm	133 mm
Longitud Estándar de Lama	6,40 ml	6,40 ml	6,40 ml	6,40 ml
Embalaje	Plástico	Plástico	Plástico	Plástico
Suministro	10 lamas	10 lamas	10 lamas	10 lamas

GAMAS DE COLORES ESTÁNDAR LAMA DE ALUMINIO DE EXTRUSIÓN

65,5 mm

BLANCO, NATURA, BRONCE, ORO, RAL 1015, RAL 3000, RAL 3005, RAL 3007, RAL 6005, RAL 6009, RAL 7011, RAL 7012, RAL 7022, RAL 7035, RAL 8014, RAL 8017, RAL 8019, RAL 9005, RAL 9010, RAL 9011

75,5 mm

95,5 mm

100,0 mm

Resto de colores RAL: Consultar

GAMA DE CARRILES COMPATIBLES

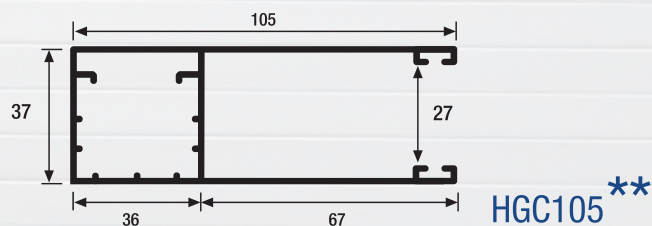
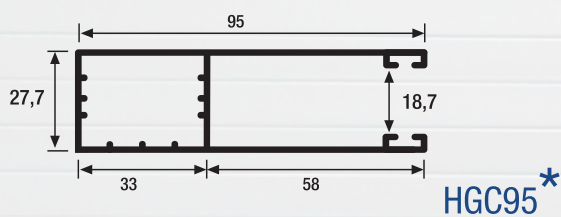
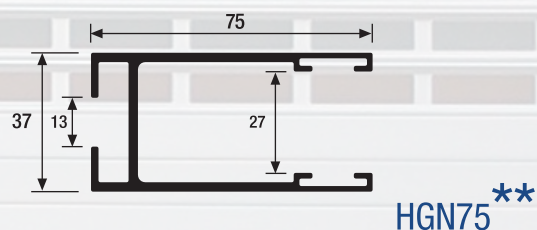
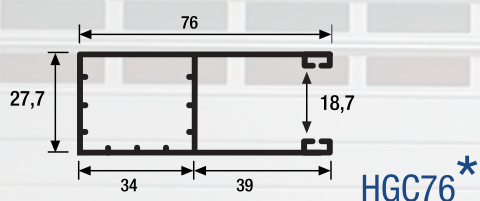
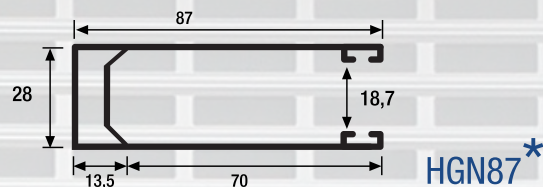
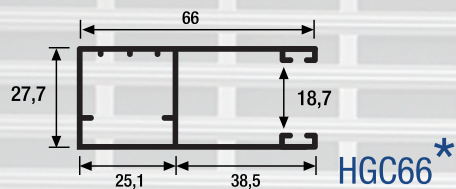

- * Para lama autoblocante 65 mm y autoblocante 75 mm
- ** Para lama autoblocante 95 mm y recta 100 mm

www.persianashernando.com

DELEGACIÓN EN MADRID

madrid@persianashernando.es

c/Carvajales 17
28005 Madrid

914 73 50 00
914 73 24 24

FÁBRICA EN SEGOVIA

segovia@persianashernando.es

c/Guadarrama 51
40006 Segovia

921 41 23 00
914 73 24 24

DELEGACIÓN EN ZARAGOZA

moncayo@persianashernando.es

Camino de Bajo Venta, nave 4
50410 Cuarte de Huerva
Zaragoza

976 50 32 18
976 50 54 46